

**FUZZYSCAN**

FuzzyScan OEM Scan Engine

# SE380 Series

Integration Guide Rev. A4

**cino**

© Copyright Cino Group

© Copyright PC Worth Int'l Co., Ltd

Cino makes no warranty of any kind with regard to this publication, including, but not limited to, the implied warranty of merchantability and fitness for any particular purpose. Cino shall not be liable for errors contained herein or for incidental consequential damages in connection with the furnishing, performance, or use of this publication. This publication contains proprietary information that is protected by copyright. All rights are reserved. No part of this publication may be photocopied, reproduced or translated into any language, in any forms, in an electronic retrieval system or otherwise, without prior written permission of Cino. All product information and specifications shown in this document may be changed without prior notice.

## **Warranty**

Cino warrants its products against defects in workmanship and materials from the date of shipment, provided that the product is operated under normal and proper conditions. The warranty provisions and durations are furnished by different warranty programs. The above warranty does not apply to any product which has been (i) misused; (ii) damaged by accident or negligence; (iii) modified or altered by the purchaser or other party; (iv) repaired or tampered by unauthorized representatives; (v) operated or stored beyond the specified operational and environmental parameters; (vi) applied software, accessories or parts are not supplied by Cino; (vii) damaged by circumstances out of Cino's control, such as, but not limited to, lightning or fluctuation in electrical power. Any defective product must follow the warranty program and RMA procedures to return Cino for inspection.

## Revision History

Rev. No.	Released Date	Description
Rev. A	May 26, 2010	First Release
Rev. A1	June 25, 2010	<ul style="list-style-type: none"> <li>* Page 14 : Modify drawings and interface connector specification</li> <li>* Page 21/22 : Modify Power Up Timing Sequence and Power Off Timing Sequence</li> <li>* Page 23/24 : Modify Timing Waveforms</li> <li>* Page 31 : Update the Technical Outline Specification</li> </ul>
Rev. A2	June 29, 2010	* Page 23 : Increase Power Up, Scan and Beep Timing
Rev. A3	Oct. 15, 2010	<ul style="list-style-type: none"> <li>* Page 6 : Modify Power Management</li> <li>* Page 7 : Add Awaken the SE380 and increase CTS, RXD approaches to wake up SE380 in low power mode</li> <li>* Page 9 : Beeper and GR_LED can be active low (default) or active high</li> <li>* Page 11: Beeper and GR_LED can be active low (default) or active high</li> <li>* Page 16: Add Handling Instructions</li> <li>* Page 17: Add Installation Instructions.</li> <li>* Page 18: Modify Optics and Illumination</li> <li>* Page 21: Add notes in Flex Cable</li> <li>* Page 32: Modify Regulatory Requirements</li> </ul>
Rev. A4	Jan 19th, 2011	* Page 10: Modify Reference Schematic

# Table of content

<b>Chapter 1 Getting Started</b>	1
1.1 Introduction	2
1.2 Theory of Operation	3
Operation Modes	3
Configuration Methods	5
Power Management	6
Awaken the SE380	7
1.3 Host Interfaces	8
1.4 Status Indications	13
<b>Chapter 2 Installation</b>	14
2.1 Mounting	15
Mechanical Characteristics	15
Handling Instructions	16
Installation Instructions	17
2.2 Optics and Illumination	18
Optical Characteristics	18
Exit Window Characteristics	19
Exit Window Requirements	20
2.3 Flex Cable	21
<b>Chapter 3 Electrical Characteristics</b>	22
3.1 AC Characteristics	23
3.2 Timing Waveforms	26
<b>Chapter 4 Specifications and Reading Capability</b>	28
4.1 Specifications	29
4.2 Scan Map	31
<b>Chapter 5 Regulatory Requirements</b>	32
<b>Appendix</b>	
A SE380 Series Technical Outline Specification	33

## **Chapter1 Getting Started**

This integration guide provides the reference information for hardware integration of Cino FuzzyScan SE380 series OEM scan engine into your desired devices. If you need more information or any enquiry about this manual, please contact your supplier for assistance.

## 1.1 Introduction

Built with the state-of-the-art FuzzyScan 2.0 Imaging Technology and ultra-compact design, the unparalleled combination of outstanding scanning performance and miniature form factor make SE380 OEM scan engine from Cino ideal for a variety of OEM applications. The SE380 represents the best value in its class and delivers the promise of a true competitive advantage.

### Miniature and lightweight form factor

The ultra-compact and lightweight form factor allows SE380 to be integrated easily into different portable and fixed OEM devices where space is limited, including hand-held or fixed scanners, mobile computers and PDAs.

### Superb readability and linear-stacked support

Thanks to FuzzyScan 2.0 Imaging Technology, the SE380 series is capable of reading low contrast, damaged, smudged and poorly-printed barcodes labels quickly and accurately. Furthermore, the SE388 supports most popular linear-stacked barcodes, including PDF, MicroPDF, Codablock, GS1 DataBar Linear-stacked and Composite.

### Overview

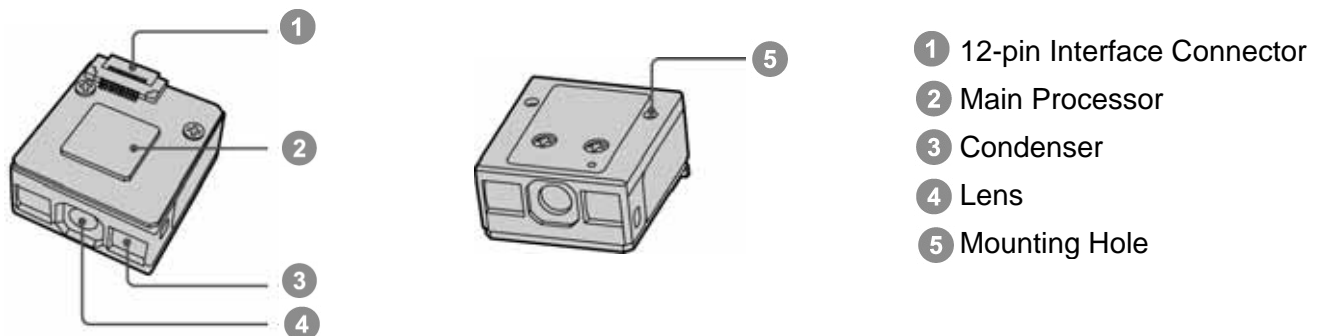

### Key Features

- Ultra-compact and lightweight for easy integration into portable and fixed OEM devices
- GS1 DataBar, PDF, MicroPDF and composite code support
- Outstanding reading capability on 3 mil barcode with more than 2" depth of field
- More than 16" reading distance on 100% UPC/EAN symbols
- Superb readability on low contrast, smudged, poorly-printed or damaged barcodes
- Superior motion tolerance for rapid and accurate data-capture on the move
- High speed scanning rate up to 500 scans per second for snappy barcode capture
- Support multiple host interfaces including RS232, USB HID and USB COM
- Low power consumption extends battery life for battery-powered devices

## 1.2 Theory of Operation

The built-in main processor of SE380 series scan engine can control the functionality of the engine, perform software decoding of bar code data and establish the communication link to the host device. In addition, the non-volatile memory can store user preferences for decoder capability parameters.

### Operation Modes

The SE380 series scan engine supports 6 different operation modes to fulfill various scanning requirements.

- **Low Power Mode (Low Power Triggering)**

The engine goes into sleep state immediately (around 100 ms) for extremely low power consumption after wake-up or each scan attempt. You must wake up the engine for operation. It is very helpful for mobile data collection and application, which are concerned with power savings.

- **Trigger Mode (External Triggering)**

The engine goes into idle state after scanning the bar code. You must activate the trigger to turn on the light source of the scanner before scanning the bar code.

- **Presentation Mode (Auto Detection)**

Presentation mode uses ambient light to detect the bar codes. The light source is off until the scanner detects an image which is similar to a barcode. Then the light source turns on automatically to read the bar code. If the light level in the room is not high enough, Presentation Mode may not work properly. You can choose different level of “Presentation Sensitivity” to meet your application (Please refer to the setting of “**Presentation Sensitivity**”).

- **Alternative Mode (Periodic Power Off)**

The scanner keeps the light source of the scanner turned on till the pre-defined light source on time is up. After the engine turns off the light source, you must activate the trigger to turn on the light source again. After each good read, the timer counter of “Light Source on Time” is reset. You do not have to activate the trigger frequently, it is very convenient for multiple scanning.

- **Force Mode (Continued Power On)**

The light source of the engine is forced on for continued operation without activating the trigger switch. This mode is convenient for high speed bar code reading.

- **Level Mode (Auto Power Off)**

When this operation mode is selected, the engine continues to turn on the light source before a good read or pre-defined “Light Source on Time”. If the scanner decodes a bar code successfully, it turns off the light source immediately. After the engine turns off the light source, you must activate the trigger to turn on the light source again. If there is no scanning operation performed during the pre-defined light source on time, the scanner enters the idle state after the pre-defined light source on time is up.



## Configuration Methods

FuzzyScan SE380 series scan engine is designed to be configured by FuzzyScan bar code commands or FuzzyScan serial commands. By using FuzzyScan bar code commands or serial commands which enable the developer to configure a complete setting for the SE380.

### ▪ **FuzzyScan Bar Code Commands**

The FuzzyScan bar code commands are specially designed “Proprietary” bar code labels which allow you to set the FuzzyScan internal programming parameters. There are “System Command”, “Family Code” and “Option Code” for programming purpose.

Each programmable family and bar code command label is listed on the same page with major system commands. The detailed explanations and special programming flowchart are printed on the opposite or following pages. You can read the explanation and set the FuzzyScan scan engine concurrently.

A supplemental bar code command menu incorporates the bar code command labels of System Command and Option Code. As you set the FuzzyScan scan engine, open the bar code command menu to find the option code page. You may scan the desired family code and option code to set FuzzyScan scan engine. If you want to change the programming family for multiple settings, you need only turn over the programming page to find next desired programming family. For more details, please refer to **FuzzyScan Scan Engine Programming Manual**.

### ▪ **FuzzyScan Serial Commands**

The FuzzyScan serial commands use the transaction-based protocol to communicate with the host device by the handshaking protocol. After a command function is called, control returns to the host application when the engine processes the command. After the command is processed by the engine, the host application receives a Windows message indicating the command was processed. The host device should provide a message handler for the acknowledgement from the connected device before initiating another command.

The Windows host program also receives Windows messages when the decoder has data to send to the host or when a timeout or error occurs. The Windows host program provides data storage for the DLL to use for returning scanner data to the application. For more details, please refer to **FuzzyScan Scan Engine FSC Manual**.

## Power Management

The SE-380 has three different power states – Awake State, Idle State and Sleep State.

When SE380 is in trigger mode, alternative mode and level mode, the engine will enter into idle state for lower power consumption after each scan attempt. When SE380 is in low power mode, the engine will enter into deep sleep state immediately (around 100 ms) for extremely low power consumption after wake-up or each scan attempt. When SE380 is in force mode or presentation mode, the engine stays in awake state always.

## Awaken the SE380 from Low Power Mode

If the SE380 enters into sleep state in low power mode, you can use one of the following approaches to wake up the engine based on the design of your OEM devices:

- **nWAKE pin**

Please refer to the following information and the hardware connection of TTL level 232 reference schematic in page 10.

- 1. Use the CPU GPIO of your OEM device**

Connect the SE380 nWAKE pin with one of the CPU GPIO (using other I/O is available) of your OEM device. Use the program to control CPU GPIO to wake up the engine.

- 2. Use the RTS pin of the RS232 serial**

Connect the SE380 nWAKE pin with CPU RS232 serial RTS pin of your OEM device. Use the program to control RS232 RTS pin to wake up the engine.

- 3. Use the RXD pin of the RS232 serial**

Connect the SE380 nWAKE pin with CPU RS232 serial RXD pin of your OEM device. Use the program sending the data through the RS232 serial to wake up the engine.

- **CTS Signal**

Pull this pin low (active low) to wake up the engine.

- **RXD Signal**

Send single character **NULL** (0x00) to wake up the engine. This character is only needed when hardware handshaking is not used or is bypassed.

Once the SE-380 has been awakened, it remains awake around **100msec** (factory preset value of “**Time Delay to Lower Power Mode**”) before re-entering Low Power mode. The host must perform its first action within the preset duration. You can extend the preset value by setting this parameter to fulfill your application requirement. For more details, please refer to the section of “Time Delay to Lower Power Mode” listed in FuzzySCan Programming Manual.

## 1.3 Host Interfaces

FuzzyScan SE380 series scan engine can support TTL Level 232, USB HID, USB COM Port Emulation, Wand Emulation and Laser Emulation for your design requirement. Please refer to the following table for your reference.

<b>Model Number</b>	<b>Host Interface</b>	<b>Remark</b>
SE380-0	TTL Level 232 (UART)	
SE380-1	USB (COM & HID)	Default Interface: USB COM
SE380-2	Wand Emulation	
SE380-3	Laser Emulation	

## TTL Level 232 (UART) Interface Pin Out

Pin No.	Signal	I/O Type	Function & Descriptions
1	Reserved	–	
2	Vin	–	<b>Power Supply Voltage:</b> 3.3Vdc±10%
3	GND	–	<b>Ground:</b> 0Vdc reference
4	RXD	I	<b>Receive Data (UART):</b> Serial input port
5	TXD	O	<b>Transmitted Data (UART):</b> Serial output port
6	CTS*	I	<b>Clear to Send (UART):</b> Serial port handshaking line
7	RTS*	O	<b>Request to Send (UART):</b> Serial port handshaking line
8	PWRDWN	O	<b>Power Down Control:</b> Open drain, must add 100K resistor pull up to Vin; when high, the engine is in low power mode.
9	BEEPER**	O	<b>Beeper:</b> Open drain, 100K pull up to Vin; idle low signal that can be an active high or active low (default) DC or PWM controlled AC signal used to drive an external beeper.
10	GR_LED**	O	<b>Good Read LED:</b> Open drain, 100K pull up to Vin; active high or active low (default) signal for driving a low current of a Good Read LED circuit.
11	nWAKE*	I	<b>Wake Up:</b> Must add 100K resistor weak pull up to Vin; when in low power mode, active low to wake up the engine.
12	nTRIG*	I	<b>Trigger:</b> Weak pull up to Vin; trigger line is an "Active Low Signal". Drive this line to low to start a scan session. Leave the signal floating and connect to Ground for the active state.
<p>Note:</p> <ol style="list-style-type: none"> <li>Signal names with the "*" modifier are asserted when at the ground level (logic 0, active low).</li> <li>Signal names with the "**" modifier are asserted when at the ground level (logic 0, active low, default) or the positive supply voltage level (logic 1, active high). You can change the parameter in accordance with the application (see FuzzyScan Programming Manual <b>I/O Active State</b>).</li> <li>Signal names without any "*" modifier are asserted when at the positive supply voltage level (logic 1, active high).</li> </ol>			



For scanning action initiation, it is required to connect the Ground and active low the TRIG pin.

## Reference Schematic

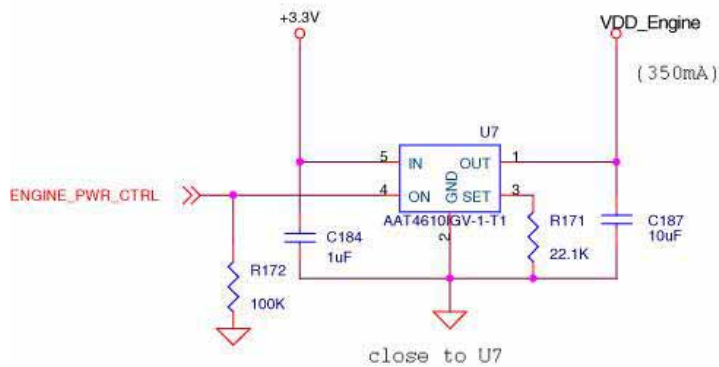
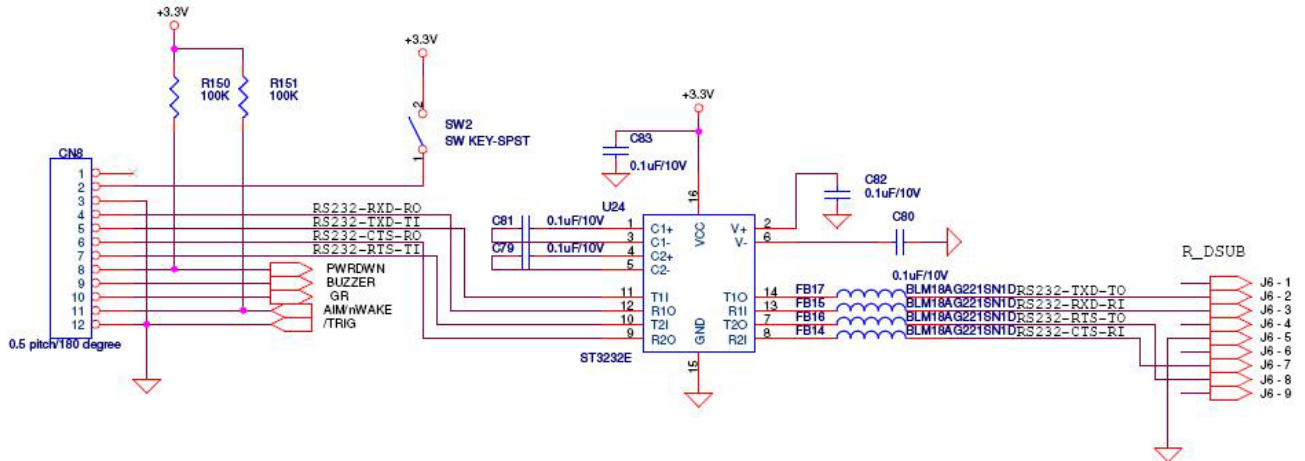

1. The SE380 scan engine system is 3.3V, and all I/O is 3.3V.
2. If use the SE380 to connect a 1.8V host or device, you need to add a Level Shifter to switch the signal.

## USB Interface (USB HID / USB COM) Pin Out

Pin No.	Signal	I/O Type	Function & Descriptions
1	No connect	–	
2	Vin	–	<b>Power Supply Voltage:</b> 3.3Vdc±10%
3	GND	–	<b>Ground:</b> 0Vdc reference
4	Data -	I/O	<b>USB Data-:</b> Bidirectional USB D- signal
5	Reserved	O	
6	Data +	I/O	<b>USB Data+:</b> Bidirectional USB D+ signal
7	Reserved	O	
8	PWRDWN	O	<b>Power Down Control:</b> Open drain, must add 100K resistor pull up to Vin; when high, the engine is in low power mode.
9	BEEPER**	O	<b>Beeper:</b> Open drain, 100K pull up to Vin; idle low signal that can be an active high or active low (default) DC or PWM controlled AC signal used to drive an external beeper.
10	GR_LED**	O	<b>Good Read LED:</b> Open drain, 100K pull up to Vin; active high or active low (default) signal for driving a low current of a Good Read LED circuit.
11	nWAKE*	I	<b>Wake Up:</b> Must add 100K resistor weak pull up to Vin; when in low power mode, active low to wake up the engine.
12	nTRIG*	I	<b>Trigger:</b> Weak pull up to Vin; trigger line is an "Active Low Signal". Drive this line to low to start a scan session. Leave the signal floating and connect to Ground for the active state.

## Note:

1. Signal names with the "\*" modifier are asserted when at the ground level (logic 0, active low).
2. Signal names with the "\*\*" modifier are asserted when at the ground level (logic 0, active low, default) or the positive supply voltage level (logic 1, active high). You can change the parameter in accordance with the application (see FuzzyScan Programming Manual **I/O Active State**).
3. Signal names without any "\*" modifier are asserted when at the positive supply voltage level (logic 1, active high).



For scanning action initiation, it is required to connect the Ground and active low the TRIG pin.

Reference Schematic

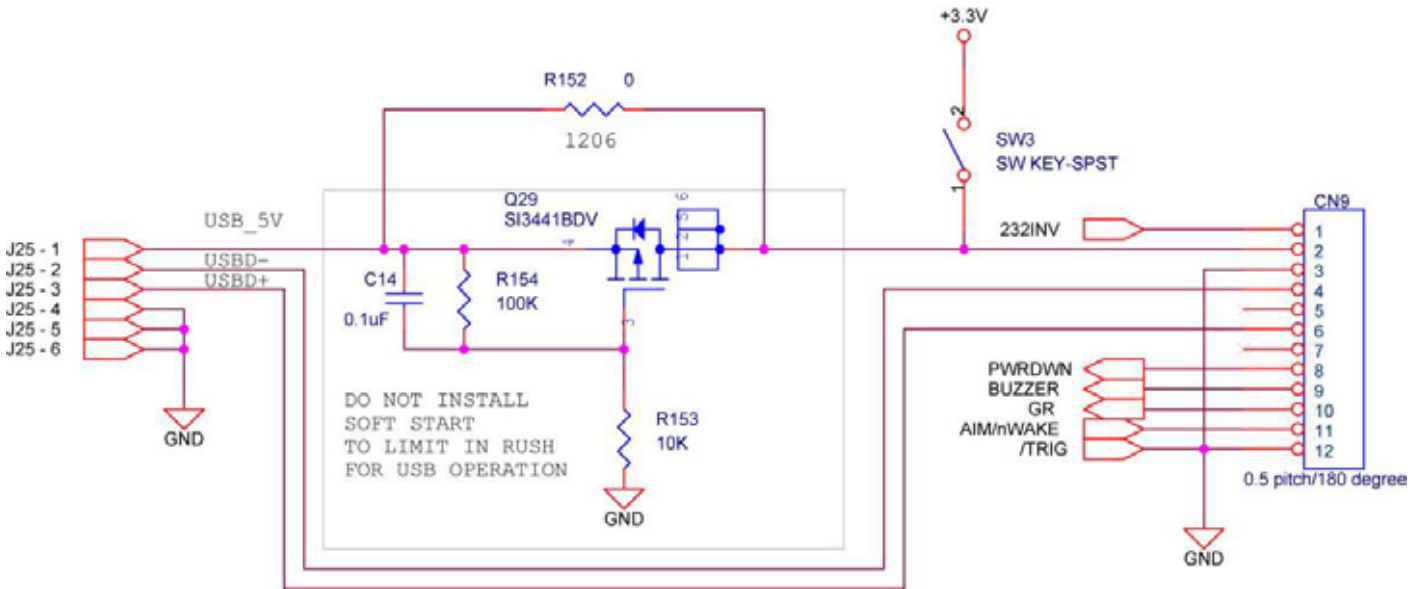

5V to 3.3V

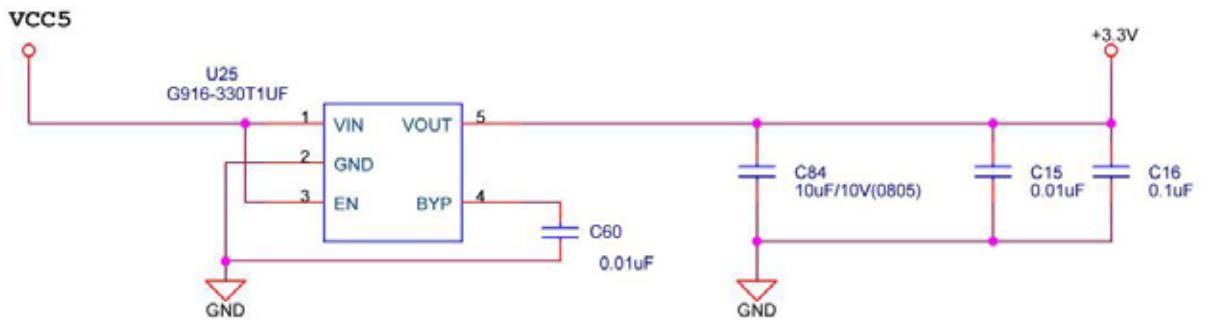



## 1.4 Status Indications

### Good Read LED

The pin on the host interface connector (GR\_LED) of the SE380 is designed to drive the LED to indicate the Good Read status.

### Beeper Definitions

The pin on the host interface connector (BEEPER) of the SE380 is designed to provide a PWM output for generating audible feedback to the user. This signal is used to indicate the different status of the device using a variety of sequences and patterns. The following table listed the beeping which occurs during normal scanning and programming the scan engine.

Beeping	Description
<b>Standard Use</b>	
1 beep	Good read
1 long beep	Invalid scan
<b>Programming Menu Scanning</b>	
3 beeps	System command
3 beeps	Quick set command
3 beeps	Program / End
3 beeps	Finish
2 beeps	Family code
1 beep	Option code

## **Chapter2 Installation**

This chapter provides information for mounting and installing the SE380 series scan engine, including mechanical and optical considerations, and recommended window requirements.

## 2.1 Mounting

There are two mounting holes which located on the bottom of the SE380 scan engine chassis. Please use a suitable TP1.7 pan head self-tapping screws for your mounting requirement. The SE380 can be mounted in any orientation without the impact in performance. Please refer to the following mechanical drawings and instructions for mounting requirement.

### Mechanical Characteristics

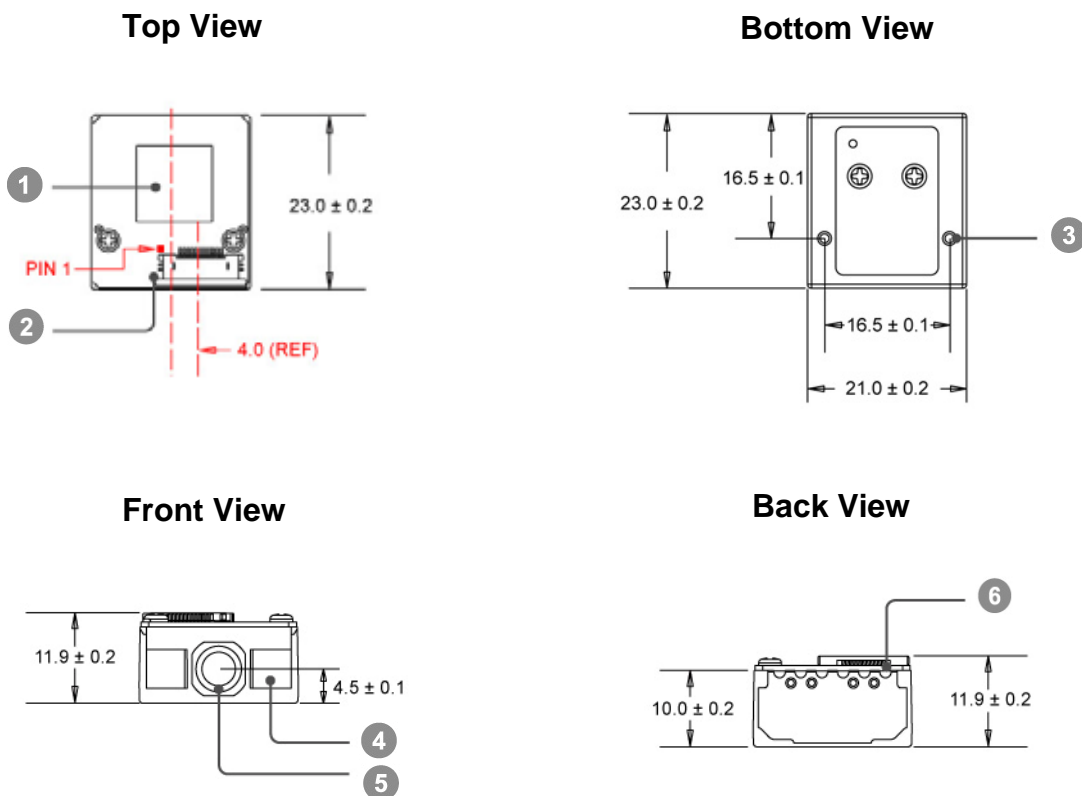

Unit = mm

Item	Description	Remark
1	Main Processor	
2	Interface Connector	12-pin , 0.5mm (0.02") Pitch ZIF FFC/FPC Connector, Downside Contact Style, Lead-free
3	Mounting Holes	1.2mm diameter hole for TP 1.7 x 5mm long (minimal) pan head self-tapping screws
4	Condensers	
5	Lens	
6	Interface Connector Port	

## Handling Instructions

Please refer to the following important notices for handling the SE380 scan engine.

- **Careful Holding**

Only hold on the case of the SE380 when handling. Do not hold on its circuit board or the front side of the SE380. Do not touch the electronic elements and circuit board.

- **ESD Protection**

The SE380 is shipped with Electrostatic Discharge (ESD) protective packaging due to the sensitive nature of the exposed electrical components for the engine. Using grounding wrist straps and handling the engine in a properly grounded work area is highly important. The housing design for mounting the engine is suggested for ESD protection and stray electric fields.

- **Thermal Consideration**

Care must be taken when designing the scan engine into any system. Internal heating of the scan engine can happen in high duty cycle scanning applications. Normally, the aimer dissipates a significant amount of power as heat. The illumination or aiming LEDs also release heat which is a major contributor to thermal increases in high use or in presentation mode.

An increase in temperature around the scan engine can cause noise levels on the imager, which may degrade the image quality. In a continuous scanning or high use environment, the scan engine temperature could rise around certain degrees. The image quality and decode performance may also be degraded.

- **Environment**

The SE380 has certain sensitive electrical and optical components that must be sufficiently enclosed to prevent airborne contaminants and foreign materials. Airborne contaminants and foreign materials will eventually cause degradation in engine's performance. Cino does not guarantee the performance of the engine when used in an exposed application.

## Installation Instructions

Please refer to the following important notices before installing the SE380 scan engine into your desired OEM device.

- **Recommend Screw and Torque**

When you install the SE380, please use the assigned mounting holes on the bottom of the SE380 scan engine chassis for installation. You are recommended to use a suitable TP1.7 pan head self-tapping screws. The length of the TP1.7 pan head self-tapping screws will depends on the thickness of the device to be mounted. But please don't screw down further than the limitation of 4mm deep mounting depth. (Please refer to the following drawing)

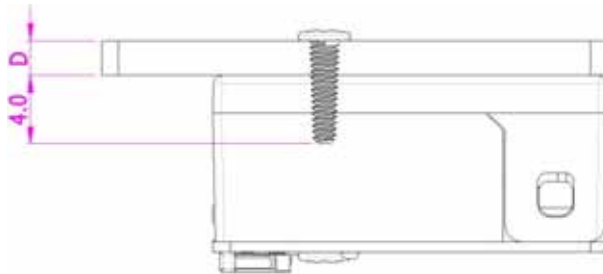

Please use tightening torque 1.0~1.5 kg-cm onto a screw when you fix the SE380.

- **Keep Enough Clearance**

Please keep enough clearance to avoid direct force onto the SE380 in case your host is dropped or deformed.

## 2.2 Optics and Illumination

The SE380 series scan engine applies a sophisticated optical system and characteristics to perform the outstanding scanning requirements. The orientation of the exit window largely effects scanner performance. In addition to providing obstacle-free paths for outgoing and incoming light, an appropriate designed enclosure can guarantee the performance of the SE380. The section provides general instructions for the scan engine into the OEM device. Before the integration, it is recommended to perform the opto-mechanical analysis by the engineer.

### Optical Characteristics

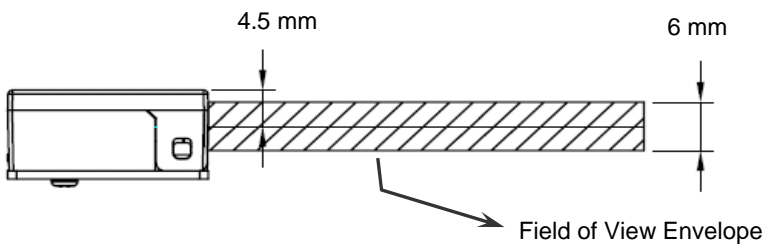
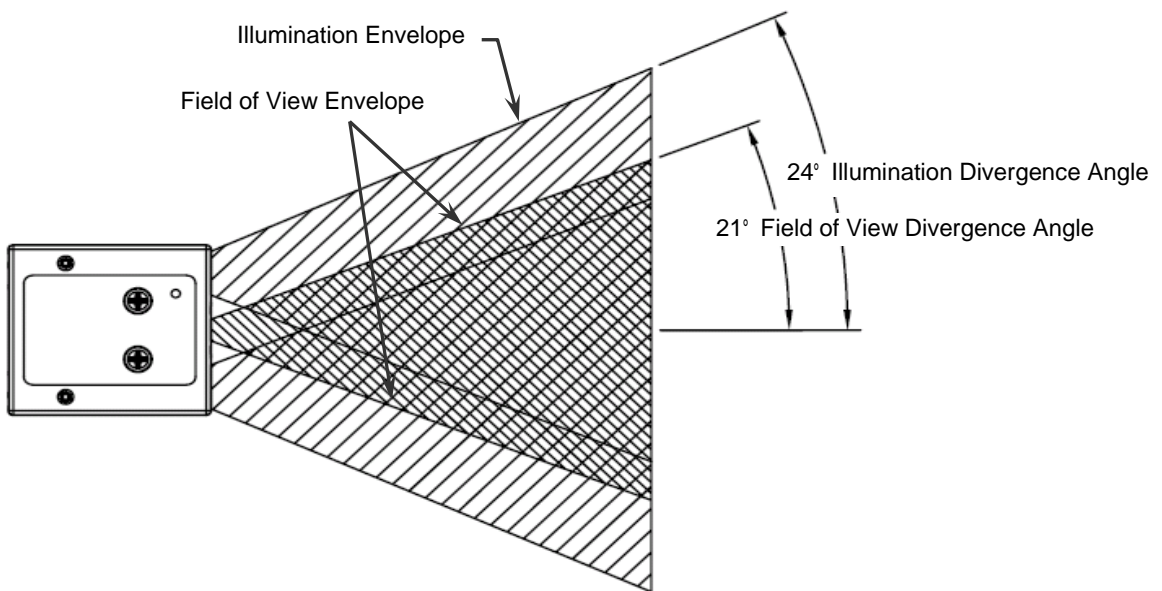

### Exit Window Characteristic

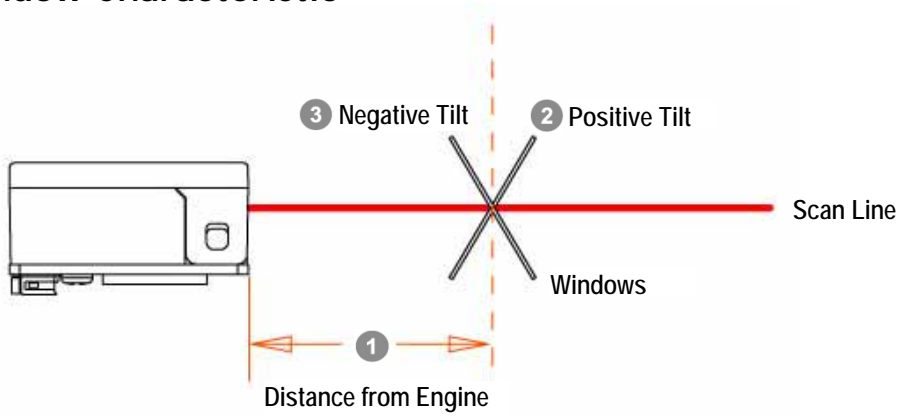

### Exit Window Tilt Angle

① Distance from Engine on Center Line (mm)	② Minimum Window Positive Tilt (degree)	③ Minimum Window Negative Tilt (degree)
0	0	0
1.5	0	0
2	0	0
2.5	27	26
3	25	24
4	23	22.5
5	22	21.5
6	21	21
7	20	20
8	18.5	18.5
9	17	17
10	16.5	16.5
12	15	15
14	14	14
18	12.5	12.5
24	11	11
30	10	10
36	8.5	8.5
44	8	8
50	7.5	7.5

1. Window is assumed non A/R coating. Illustrated window position is at the inner surface.
2. The above window tilt angle is only for theoretical reference, the actual tilt angle could be reduced by the proper window setting. It is recommended to test actual window tilt angle by an opto-mechanical engineer.

## Exit Window Requirements

### Window Distance and Angle

- Window location is measured from the engine front to the farthest surface of window.
- The distance between engine front and window is ideal to be set as close as possible.
- For the best scanning performance, the exit window angle is recommended to be positioned parallel to the engine front. You may refer to the table of “Exit Window Tilt angle” to configure your desired window distance and angle. It is important adjust proper window tilt angle to prevent scan line reflection.

### Window Material and Size

- The window material must be clear and optically flat, and free of scratches, pits, and seeds.
- Window size depends on distance from the engine and tilt angle, but window should be large enough to allow illumination and field of view envelopes to pass through unobstructed.

### Window Coatings

- **Anti-Reflection Coatings**

Anti-reflection coatings can be used to the inside or outside of the window to reduce the possibility of internal light reflection interfering with the performance of the engine. However, AR coatings have very poor abrasion and scratch resistance which only apply single side AR coatings in most applications (normally the AR coated side of the window faces the interior of the engine). The use of AR coating is not recommended if extended working range is required.

- **Polysiloxane Coatings**

Applying polysiloxane coatings to the surface can improve the surface resistance to both scratch and abrasion. Recessing the window into the housing can also provide additional protection against surface damage such as scratches and chips.

### Reflective Material

- Highly reflective objects in the engine’s field of view can cause bright spots to appear in the image and increase the amount of time needed to read the image. Please keep highly reflective components out of the engine’s field of view. If such components must be within the engine’s field of view, it is necessary to block or shield them to avoid this problem from occurring.



## 2.3 Flex Cable

The SE380 series scan engine connector uses 12 pin to 12 pin, 0.5mm pitch flex cable to connect the engine with the host interface. The following diagram shows a suggested pin-to-pin flex cable for your reference.

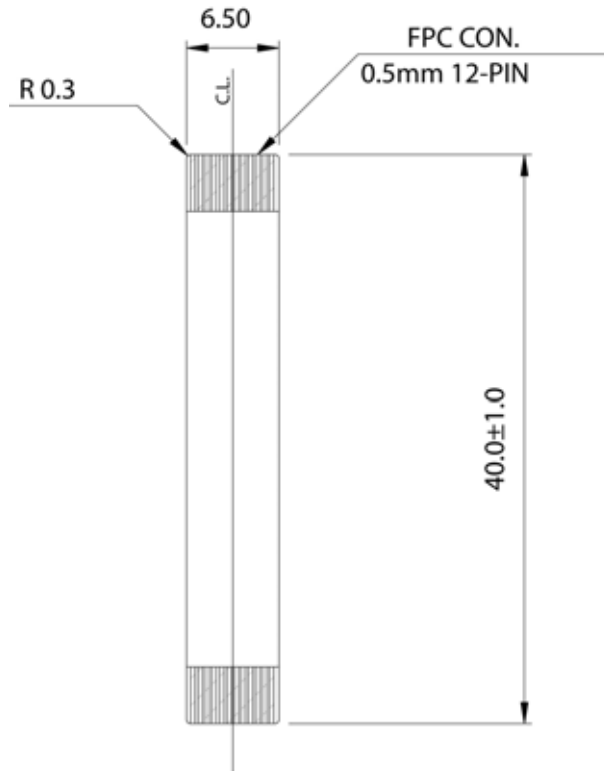

- 📝
 1. Proper flex cable design is critical to achieving adequate EMI results. The length and routing path of the flex can play big roles in the EMI signature of a product. A short list of considerations when designing with flexes follows:
  - Length      Shorter is better. Flexes tend to act like antennas; the longer they are, the more EMI transmission and reception can occur.
  - Routing      Keep the flex from passing over other high frequency components or input/output paths. This helps to reduce coupling in or out of the flex. Also, as a rule, avoid loops in the flex. Loops can add to the antenna effect.
2. Do not connect a flex cable to or disconnect a flex cable from the host interface connector when power is present on the flex cable. This could damage the SE380.

## **Chapter3 Electrical Characteristics**

This chapter includes the information about AC electrical characteristics and timing waveforms.

### 3.1 AC Characteristics

The following diagrams indicate the typical timing for the Power Up, Power Off, Scan and Decode sequence.

#### Power Up Timing Sequence (Trigger Mode)

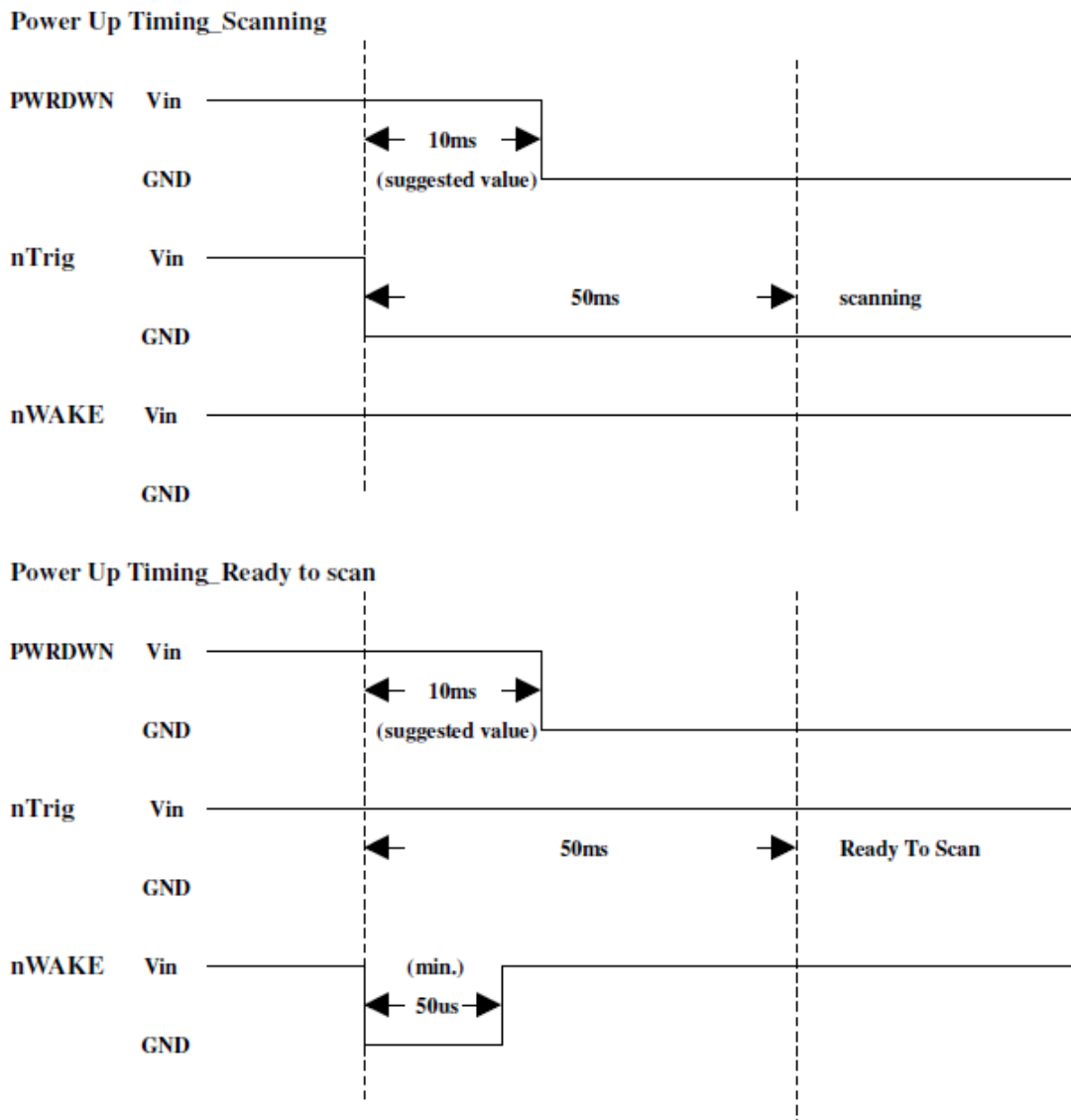

It takes some time to wake up the engine from low power mode. It's suggested to wait for 10 msec before scanning. The nWAKE pulse needed to pull low for minimal 50 microseconds.

### Power Off Timing Sequence (Trigger Mode)

Power Off Timing Sequence

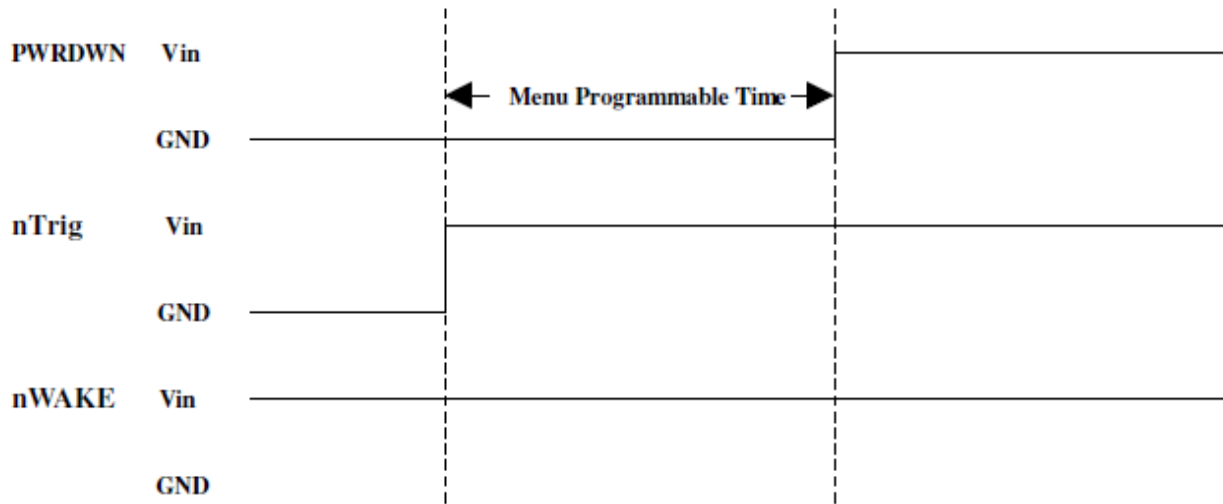

Power Up, Scan and Beep Timing (Trigger Mode)  
(Showing TRIG, BEEPER, GR\_LED)

Power Up, Scan and Beep Timing

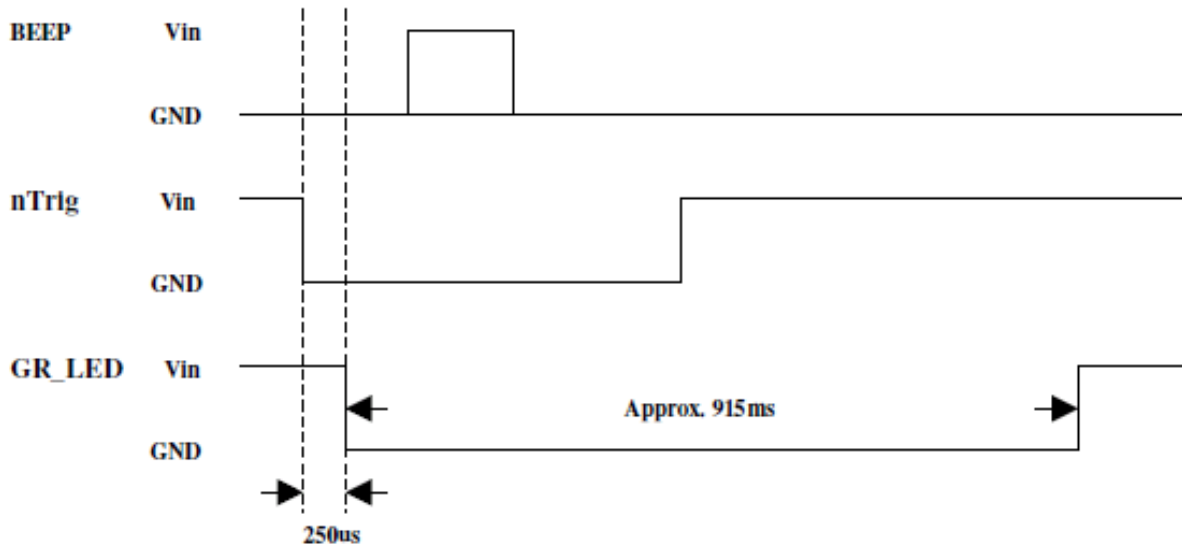

Power Up, Scan and Beep Timing (Trigger Mode)  
(Showing TRIG, RTS, GR\_LED, TXD)

Power Up, Scan and Beep Timing

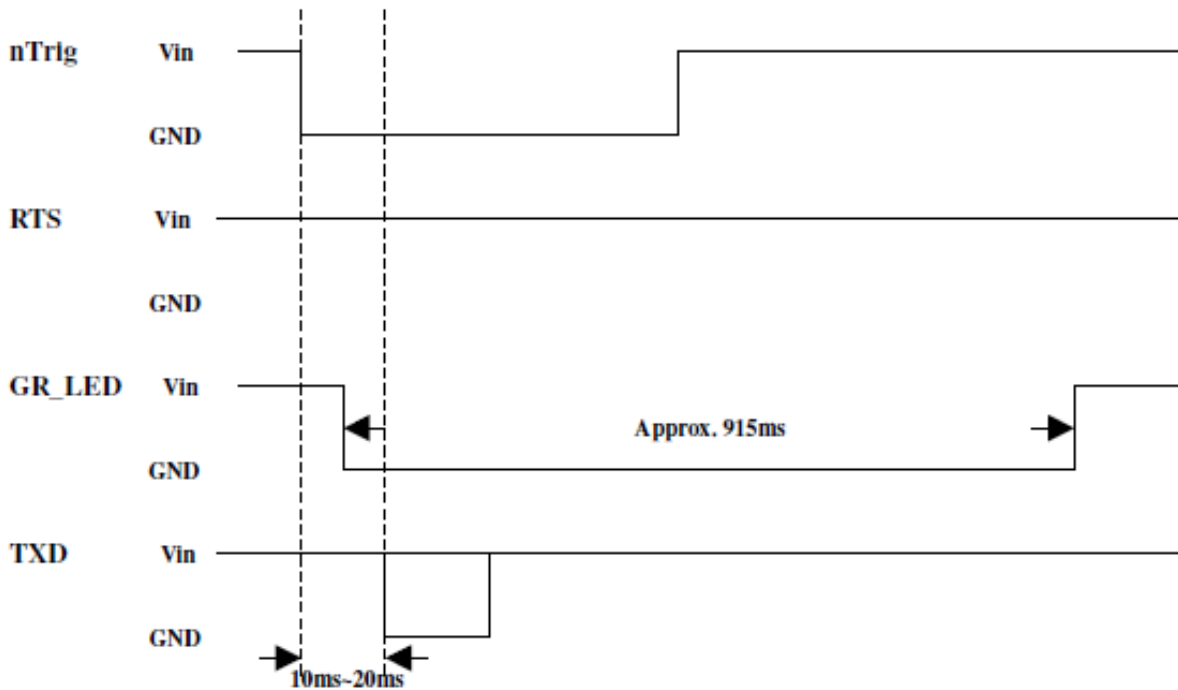

1. Assumes good quality EAN13 barcode label placed at optimum focus point (Redundancy Level 1).
2. Assumes 100k pull-up to Vin.

### 3.2 Timing Waveforms

The following interface timing waveforms may be used for reference design. The diagrams indicate the timing signals as they originate from the imager, and timing relationship that is required at the decoder board connector.

#### Power Up From Low Power Mode (Trigger Mode)

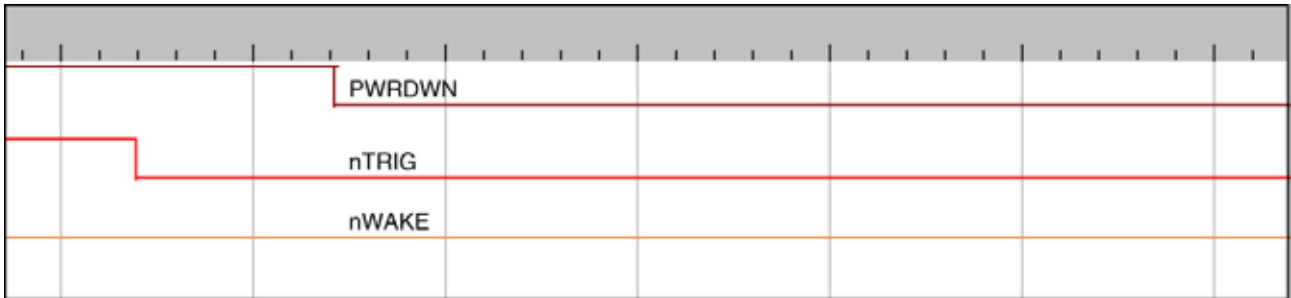

#### Enter Low Power Timing (Trigger Mode)

After nTRIG is released it takes menu programmable time for PWRDWN signal to go high.

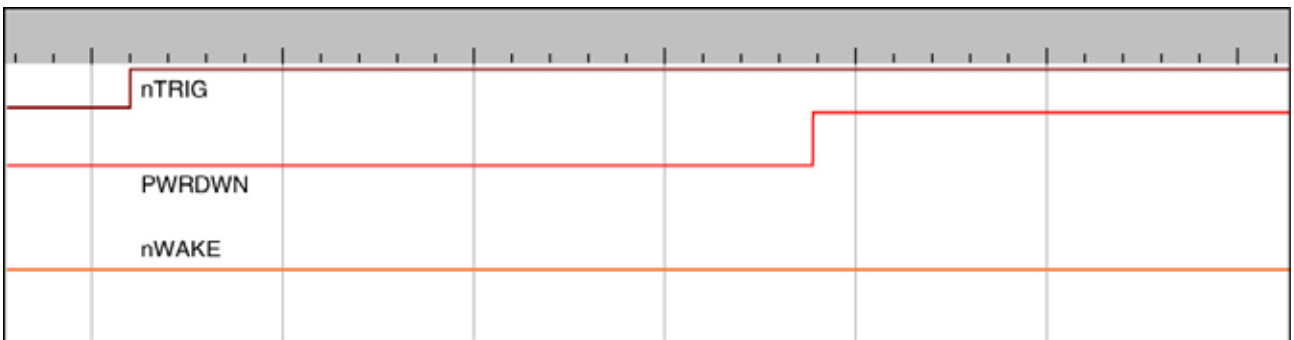

After nWAKE is released it takes menu programmable time for PWRDWN signal to go high.

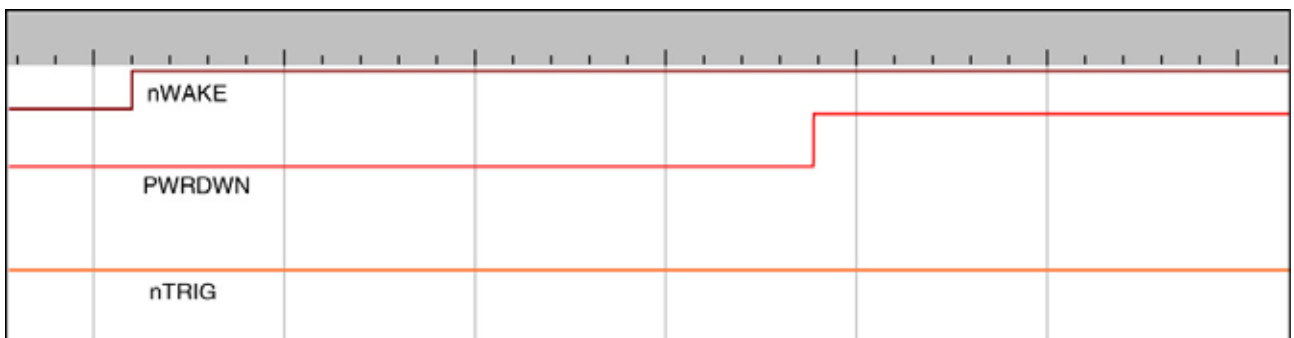

### Power Up, Scan and Beep Timing (Trigger Mode)

Showing TRIG, BEEPER, GR\_LED

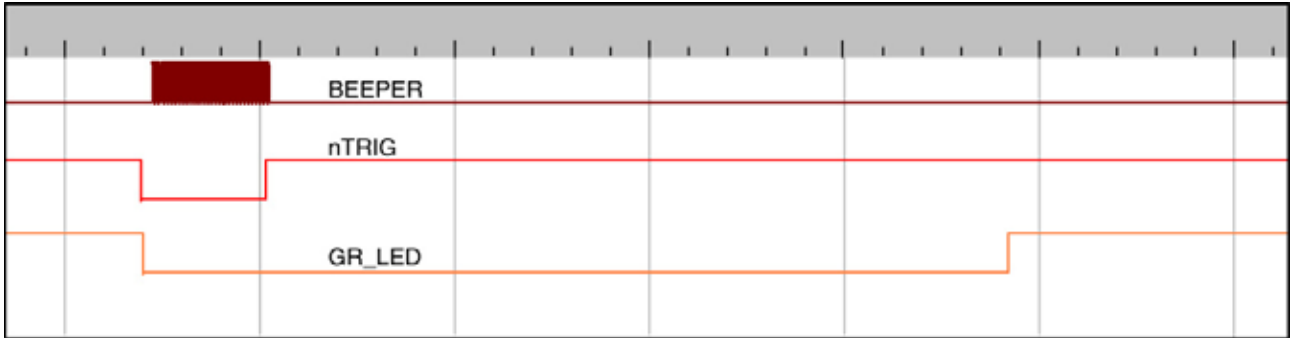

### Power Up, Scan and Beep Timing (Trigger Mode)

Showing TRIG, RTS, GR\_LED, TXD

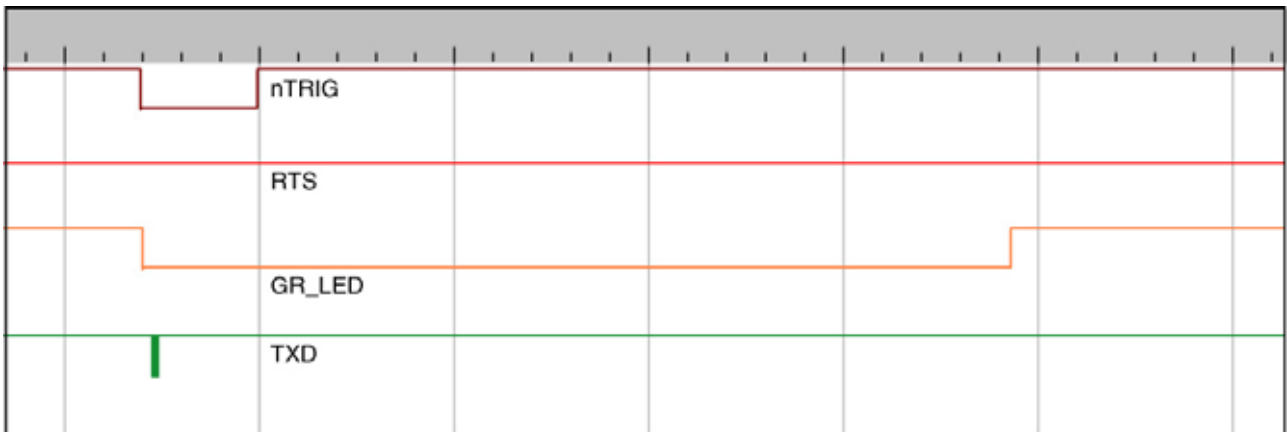

## **Chapter4 Specifications and Reading Capability**

This chapter provides specifications and reading performance of SE380 scan engine. You can refer to the following scan map to evaluate the scan engine performance.



## 4.1 Specifications

### Performance Characteristics

Optical System	High performance Linear Imaging Engine
Print Contrast	20% minimum reflective difference
Minimum Resolution	Typical 3 mil (code39, PCS - 0.9)
Working Distance	More than 16 inches on 100% UPC/EAN symbols
Light Source	630nm visible red LED
Scan Rate	Dynamic scanning rate up to 500 scans per second
Reading Direction	Bi-directional (forward and backward)
Pitch / Skew	± 65 / 55 degrees
Operation Modes	Trigger , Presentation, Force, Level, Alternative, Low power
Host Interfaces	TTL RS-232 serial USB HID (USB Keyboard) USB COM port Emulation
Configuration Setup	Bar code commands Serial commands
Data Editing	Condensed DataWizard via bar code manual Full-feature Datawizard via FuzzyScan PowerTool

### Supported Symbologies

1D Linear (SE380)	Code 39, Code 39 Full ASCII, Code 32, Code 39 Trioptic Code 128, UCC/EAN-128, Codabar, Code 11, Code 93 Standard & Industrial 2 of 5, Interleaved & Matrix 2 of 5 German Postal Code, China Postal Code, IATA UPC/EAN/JAN, UPC/EAN/JAN with Addendum Telepen, MSI/Plessey & UK/Plessey GS1 DataBar (formerly RSS) Linear & Linear Stacked
Linear-stacked (SE388)	PDF417, Micro PDF417, Codablock, GS1 Data Bar Linear-stacked and Composite

### User Environment

Operating Temperature	-20°C to 60°C (-4°F to 140°F)
Storage Temperature	-40°C to 70°C (-40°F to 158°F)
Humidity	5% to 95% related humidity, non-condensing
Ambient Light Immunity	0-100,000 lux

\* The working distances are measured in 400lux office environment using Grade A bar codes.

### Physical Characteristics

Dimension	23.0 mm (L) x 21 mm (W) x 11.9mm (D) 0.91 in. (L) x 0.83 in. (W) x 0.47 in. (D)
Weight	6 g
Input Voltage	3.3VDC $\pm$ 10%
Current	Scanning : Typical 145 mA @3.3VDC Standby : 50 $\mu$ A @3.3VDC
Connector	12-pin low profile

## 4.2 Scan Map

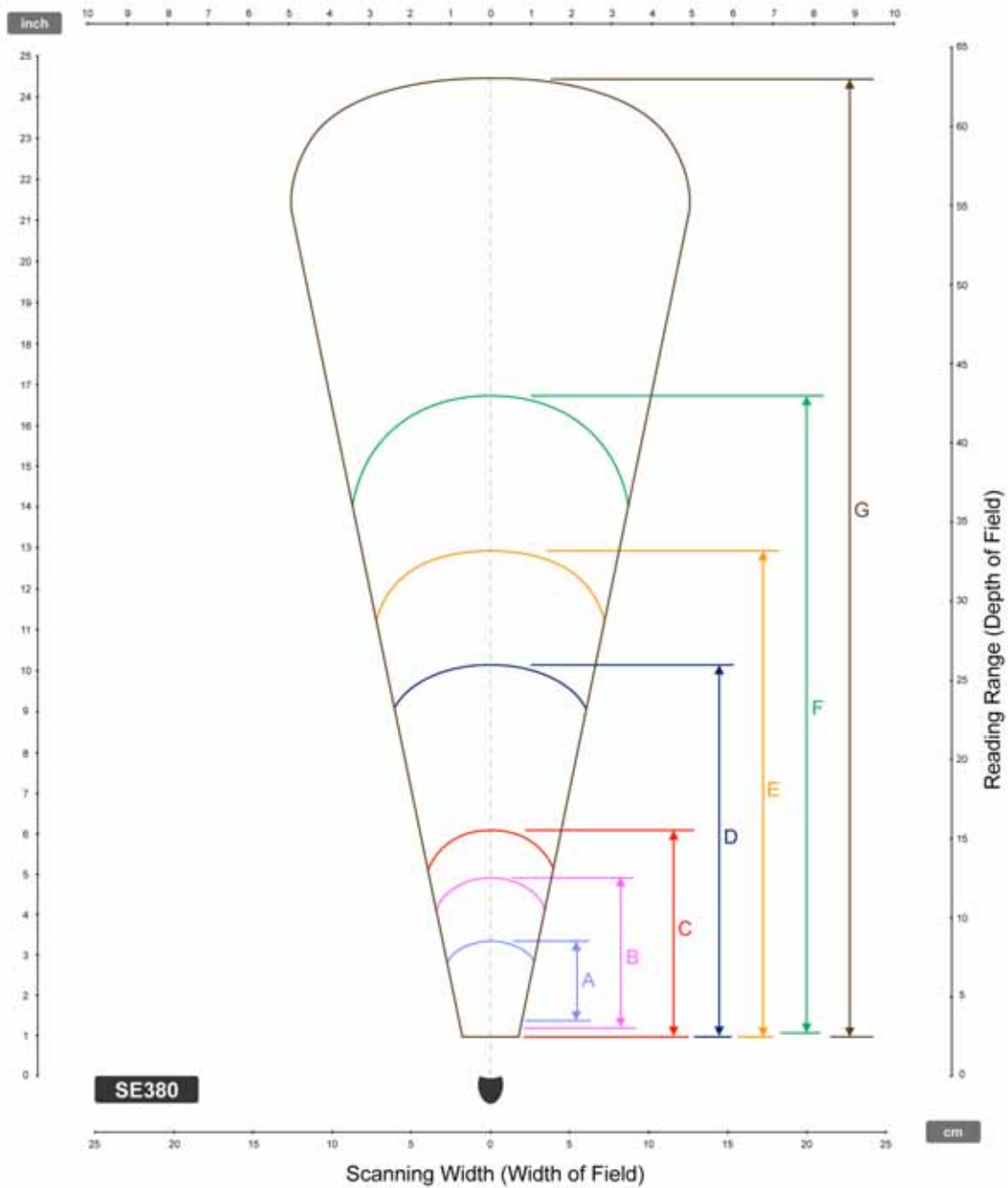

	Barcode Types	Narrow Bar Widths	Reading Ranges
A	Code 39	0.076 mm ( 3 mil )	3.5 to 8.5 cm ( 1.38" to 3.35" )
B	Code 39	0.104 mm ( 4 mil )	3.1 to 12.5 cm ( 1.22" to 4.92" )
C	Code 39	0.13 mm ( 5 mil )	2.5 to 15.5 cm ( 0.98" to 6.10" )
D	Code 39	0.20 mm ( 8 mil )	2.5 to 26.0 cm ( 0.98" to 10.24" )
E	EAN -13	0.26 mm ( 10 mil )	2.5 to 33.5 cm ( 0.98" to 13.19" )
F	UPC-A	0.33 mm ( 13 mil )	2.7 to 43.0 cm ( 1.06" to 16.93 " )
G	Code 39	0.50 mm ( 20 mil )	2.5 to 63.0 cm (0.98" to 24.80" )

 The reading ranges are measured in approximate 400 lux office environment using Grade A bar codes. (PCS=0.90 ± 0.07; Code39 with 1:2.5 narrow/wide ratio; general purpose UPC/EAN bar codes)

## **Chapter5 Regulatory Requirements**

SE380 series scan engine is designed to conform with various regulatory approvals and RoHS. However, it is the OEM manufacturer's responsibility to comply with the applicable regulatory requirements in regard to standards for specific equipment combinations.

The SE380 complies with LED Eye Safety and RoHS.

### **LED Eye Safety**

The SE380 series scan engine has light emitting diodes (LEDs) which create the illumination line. These LEDs have been tested to demonstrate that the engine is safe for its intended application under normal usage conditions. The SE380 series scan engine is designed to conform "IEC60825-1:1993+A1+A2" and "EN60825-1:1994+A2+A1" (Class 1, LED safety level).

### **RoHS**

The SE380 series scan engine is in compliance with Directive 2002/95/EC, Restriction of the Use of Certain Hazardous Substances in Electrical and Electronic Equipment (RoHS).

# Appendix

## A. SE380 Series Technical Outline Specifications

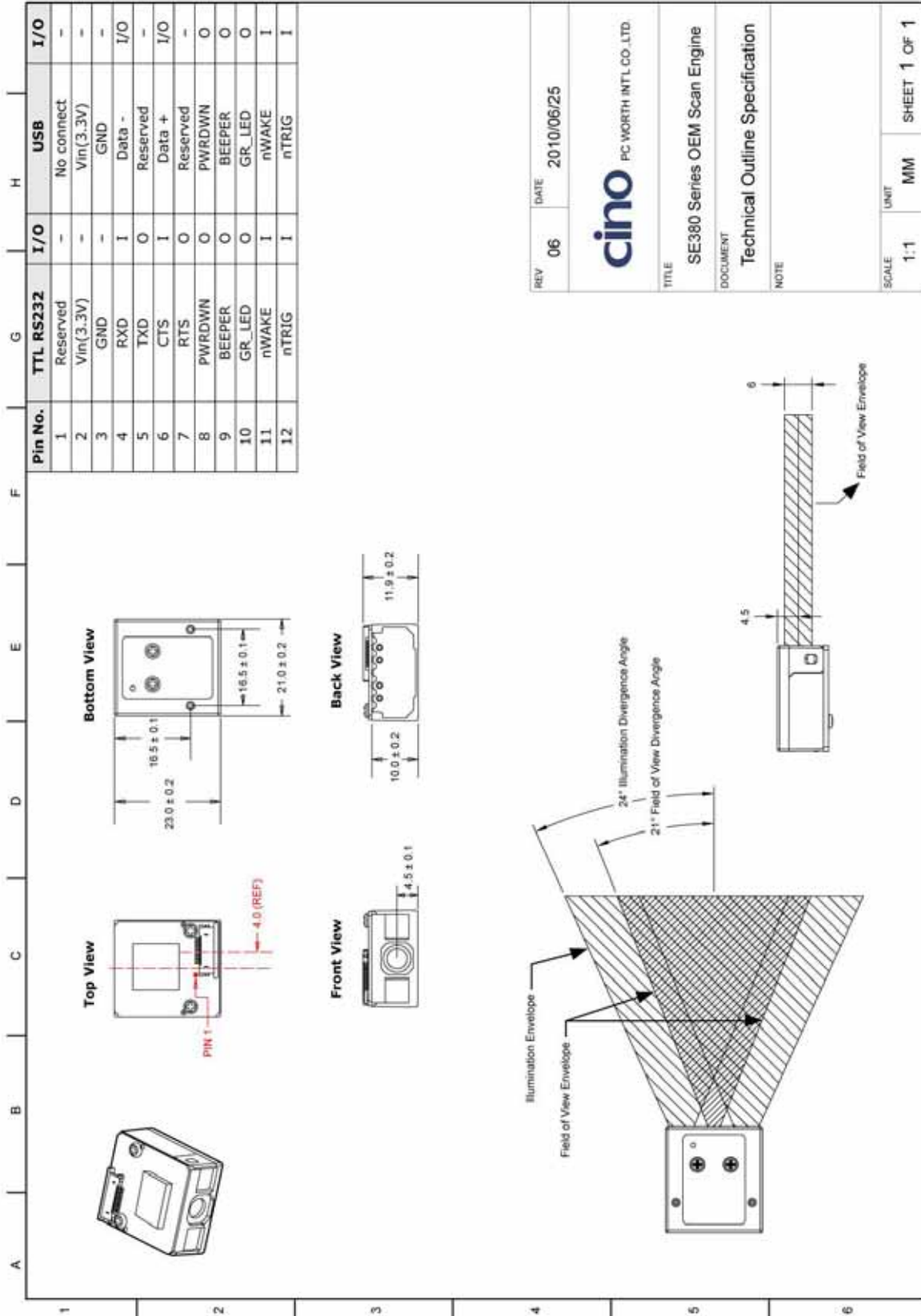

 [www.cino.com.tw](http://www.cino.com.tw)

## FuzzyScan Scan Engine Integration Guide

CINO GROUP  
PC WORTH INT'L CO., LTD.

